

# Mumby Manufacturing Ltd.

Ph: (306) 682-1477 Toll Free: 1-888-682-1477 Fax: (306) 682-2028

Email: mumbyhitches@sasktel.net Website: www.mumbyhitches.com

## **INSTALLATION INSTRUCTIONS**

### **MUMBY REMOVABLE BALL GOOSENECK HITCH**

**Model MUM – 0494**

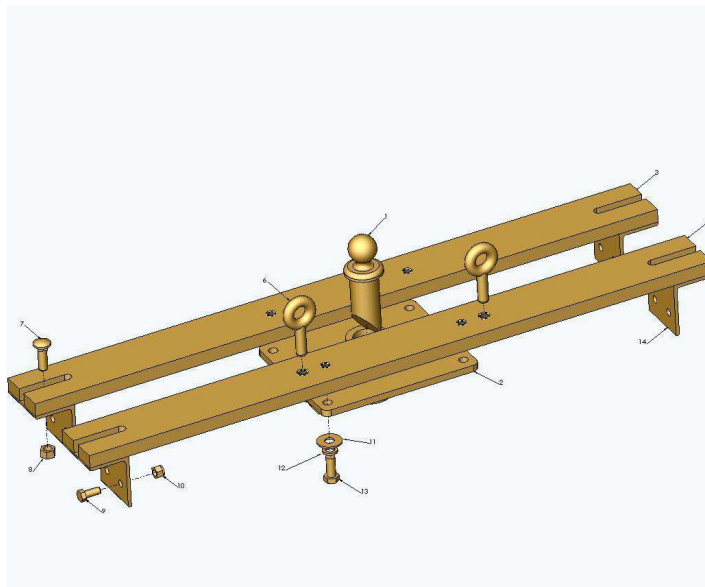

1. Drill a 3" hole, centered between the wheel wells, and 1" - 5" ahead of the axle, making sure that you are at least 6¼" from the nearest cross member (floor support) under the box. **SEE MEASUREMENT CHART BELOW.**
2. Slide the support plates between the frame and the truck box, above the wheels. The 1"x4"x47" plate is the back plate and the 1"x4"x49" plate is the front plate. More working space can be made by jacking up the rear of the truck up slightly.
3. Bolt the ball assembly loosely to the bottom of the plates with 5/8" hex-head bolts so that the release lever is to the side of the ball socket. Block the plate height, so that the top of the ball receiver is approximately 1/8" beneath the high corrugation in the floor of the truck box. (On some trucks, washers can be used as spacers to lower the ball assembly.)
4. Bolt angle brackets to the bottom of the plates, outside of the truck frame, with carriage head bolts. Now tighten the ball assembly to the plates.
5. Now that the receiver is at the desired height, and centered in the hole in the floor, drill ½" holes in the truck frame, matching the holes in the angle brackets, and fasten with ½" hex head bolts.

**TIP:** It is easier to hold the front 1/2" nut in place inside the frame, if a wrap of electrical tape is placed around the nut and the nut inserted into a 3/4" wrench socket.

**BE SURE ALL LINES & WIRES ARE OUT OF THE WAY BEFORE DRILLING.**

6. Drill two 1/2" holes 5" and 5 3/4" from the centre of the 3" hole (off to the side) to accommodate the lever used to release the ball latch and to provide a view of the locking indicator.
7. A packet of an anti-seize compound has been included with the new hitch. Open the packet and lightly cover the shank of the ball with the contents. The locking pin has been pre-coated at the factory. For proper maintenance, the ball **MUST** be removed regularly and the shank of the ball and the locking pin cleaned and lightly coated with a light lubricant or an anti-seize compound. Periodic lubrication and cleaning of the ball shank is necessary for your removable ball hitch to keep performing properly.

**AN APPROXIMATE GUIDELINE FOR BALL PLACEMENT IN VARIOUS TRUCKS**

**Note:** Measure from the back end of the floor of the truck box forward to the center of the ball. All measures are approximates. Drill a pilot hole first, then check to make sure you are at least 6 1/4" from the nearest cross member.

<b>FORD</b>	<b>YEAR</b>	<b>DISTANCE</b>
Short box F150, F250, F350	1986 +	44.5"
Long box F250, F350	1986 +	47"
Long box F150	1997 +	46"

<b>CHEV &amp; GMC</b>	<b>YEAR</b>	<b>DISTANCE</b>
Short box	1987 +	39"
Long box	1987 +	
Ext Cab Long Box dually	2003	46.5"

<b>DODGE</b>	<b>YEAR</b>	<b>DISTANCE</b>
Short box	1994 - 2002	40.5"
Long box	1994 - 2002	45.5"
3/4 ton & 1 ton	2003	See installation instr.

**Components in the MUM – 0494**

<u>Quantity</u>	<u>Description</u>	<u>Quantity</u>	<u>Description</u>
1	- Ball Assembly (Includes Ball)	1	- Release lever
1	- 47" Plate	1	- Storage Case
1	- 49" Plate	1	- Safety Chain Plate
1	- Bolt Kit	1	- Plastic Plug
4	- 4" mounting brackets		